

A  
SCALE: 1 : 2

Before cutting the profile, drill  $\phi$  5mm hole at the corner to prevent stress concentration

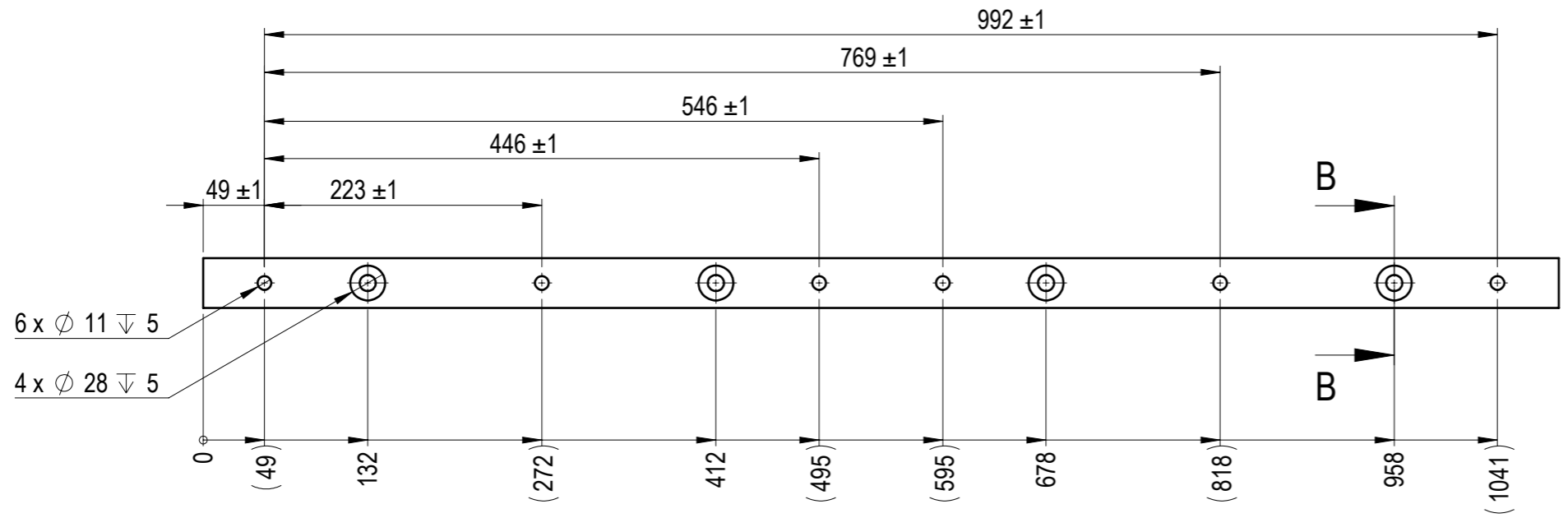

B-B  
SCALE: 1 : 1

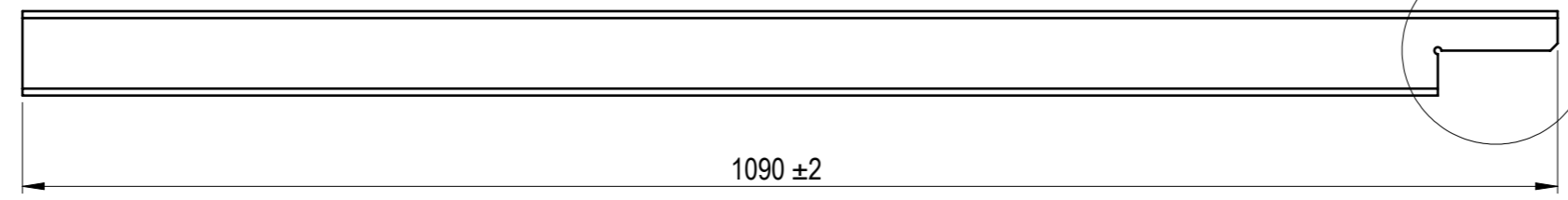
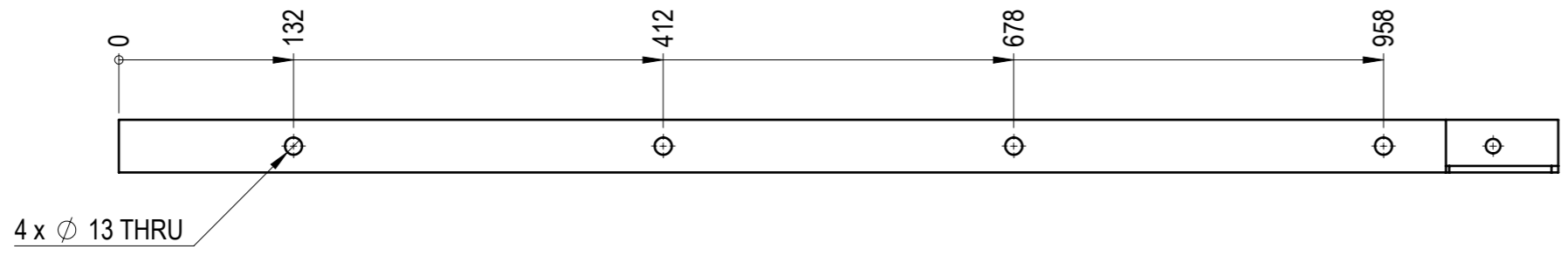
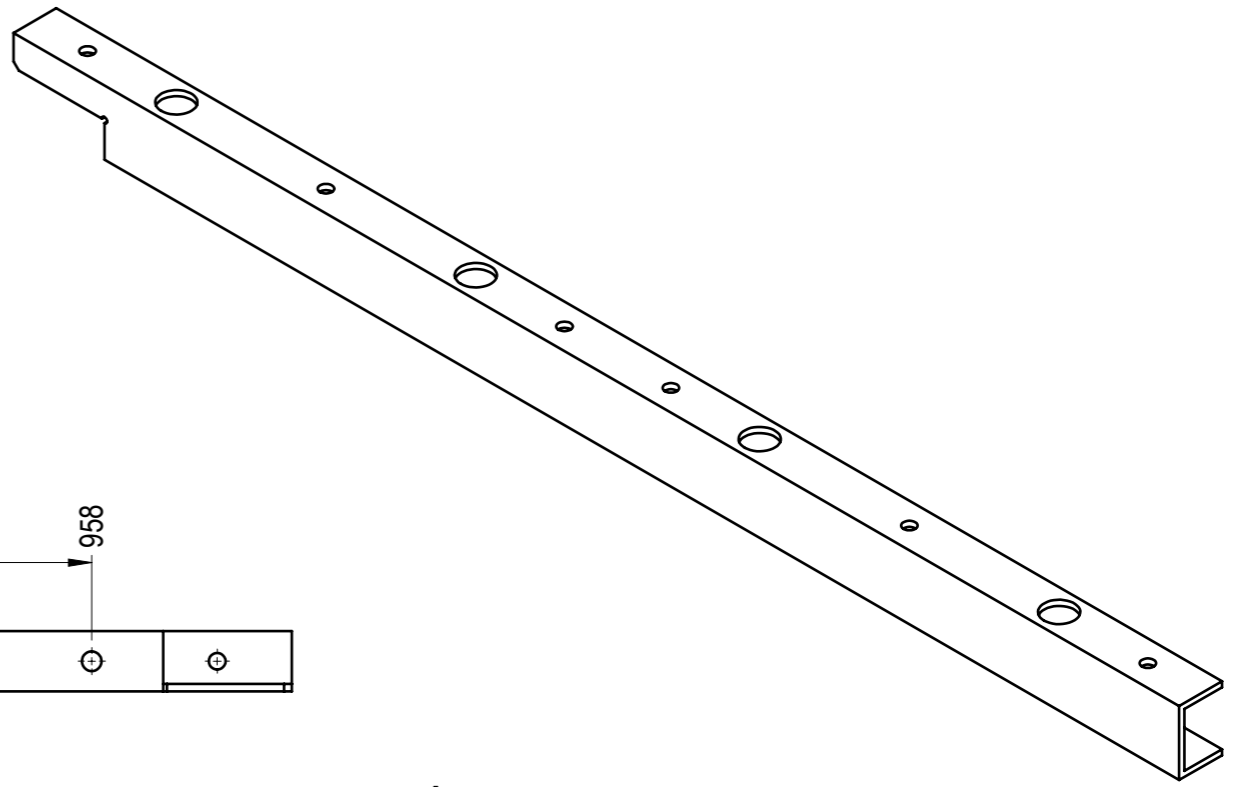
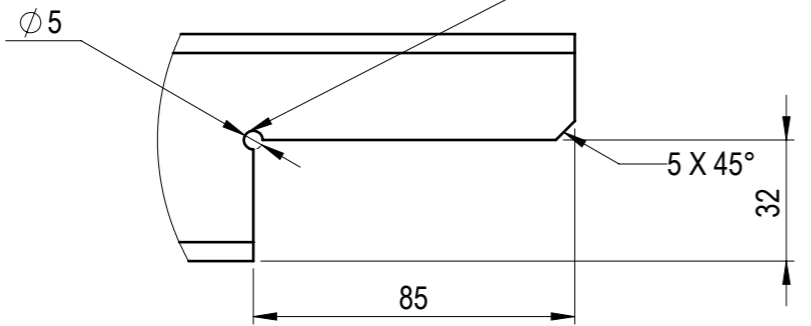
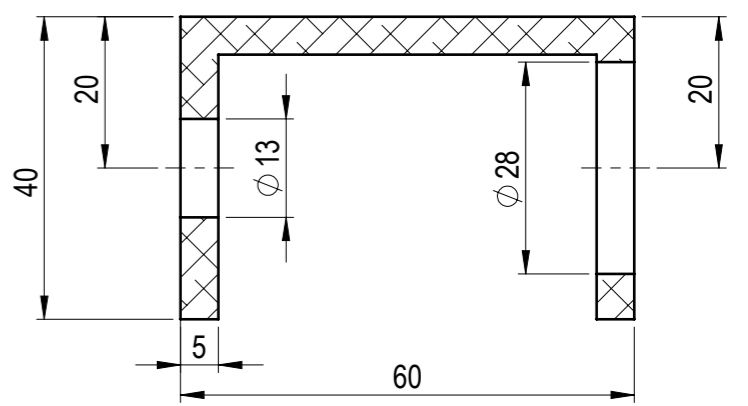

RAW MATERIAL INFORMATION	
Profile size	U 40x60x40x5
Length, mm	1090

	MATERIAL	6060F22 T6	WEIGHT	1.788 Kg	DEBURR AND BREAK SHARP EDGES	REVISION	DATE
	SURFACE PROTECTION	Anodizing ISO 7599:2010	MACHINING	ISO 2768 mK	THERMAL CUTTING	WELDING	SCALE
	NAME	SIGNATURE	PART NO.	105-11204-01			
Designed by	D. Dislers		DESCRIPTION	Aluminum U-profile 6		SHEET 1/1	
Drawn by	D. Dislers						
Technical ref.							